

~ NOTES ~

1. TRANSITION CONDITION NO. 1, 2 AND 3 ALONG WITH SYMMETRICAL AND ASYMMETRICAL BARRIER SECTIONS ARE DEPICTED ON THIS DRAWING FOR ILLUSTRATION PURPOSES ONLY AT STRUCTURES AND FIXED OBJECTS. (SEE PLANS FOR ADDITIONAL DETAILS)
2. ALL PAVEMENT, FILL MATERIAL, PIPE DRAINAGE (EXCLUSIVE OF WEEP HOLE PIPE) PLACED BETWEEN SEGMENTS OF THE BARRIER SHALL BE SHOWN SEPARATELY OR INCLUDED WITH OTHER LIKE PAY ITEMS ON THE PROJECT.
3. FOR APPLICATION DETAILS SEE CURRENT STANDARD DRAWING **RBM-050** THE METHOD OF MEASUREMENT FOR CONCRETE MEDIAN BARRIER FOR EACH TYPE WILL BE IN LINEAR FEET MEASURED ALONG THE TOP CENTERLINE OF THE BARRIER.

BID ITEM AND UNIT TO BID

CONCRETE MEDIAN BARRIER TYPE \oplus \oplus \star (50) LF

\oplus 12, OR 14 DEPENDING ON "W"

\oplus A, B OR C DEPENDING ON PAVEMENT APPLICATION.

\star 1 = SOLID SEGMENT- DENOTES BARRIER WALL WITH:

- a. TRANSITION FROM "W" WIDTH TO MAX. WIDTH OF 4'.
- b. CONSTANT WIDTH WALL GREATER THAN "W" WIDE BUT NOT GREATER THAN 4' WIDE. (EX.: WALL BETWEEN BRDG. PIERS).

2 = SEPARATE SEGMENT

$\textcircled{4}$ SEE ELSEWHERE IN PLANS FOR LOCATION AND PAYMENT FOR RACEWAY WHEN REQUIRED.

$\textcircled{5}$ 4" PIPE FOR WEEP HOLES SPACED ON 20' CENTERS AND STAGGERED 10' WITH EACH WALL.

$\textcircled{6}$ VARIABLE WIDTH

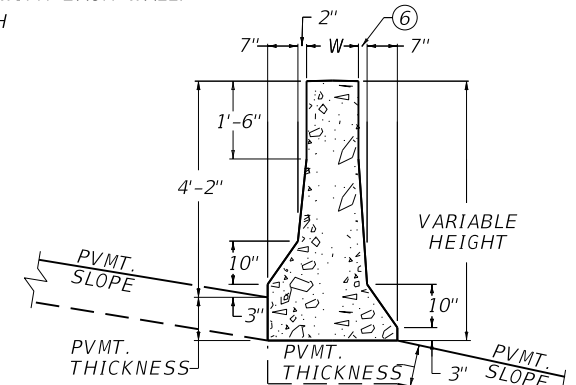
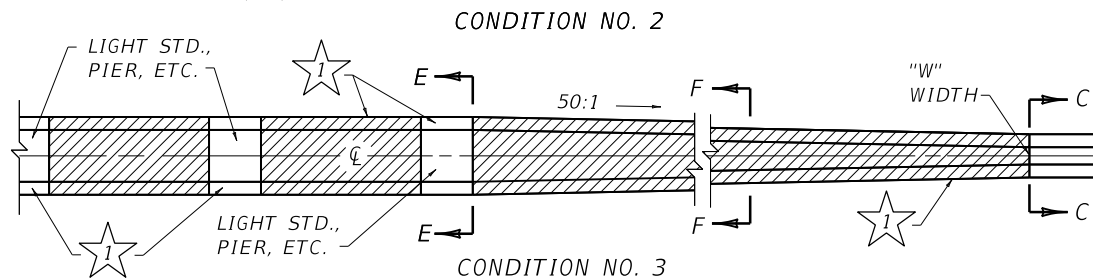
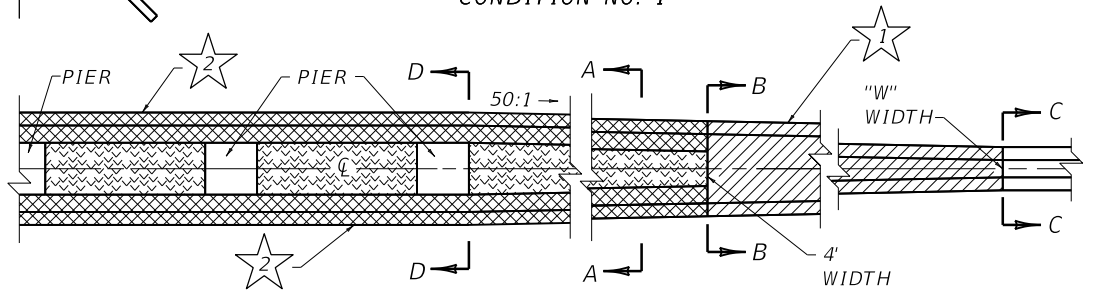
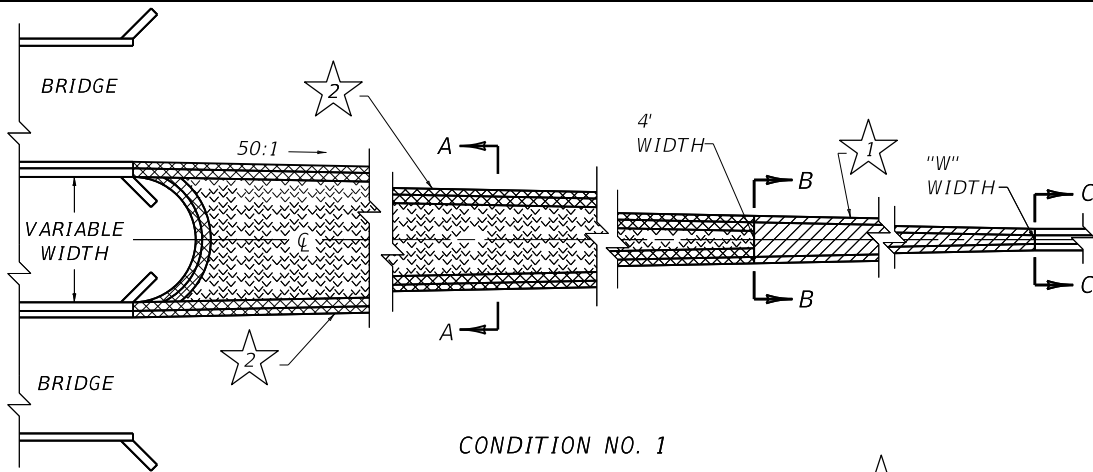

ASYMMETRICAL WALL SECTION

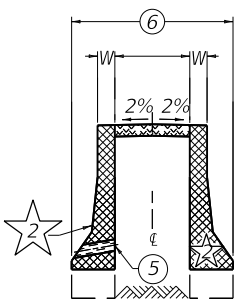

SECTION A-A

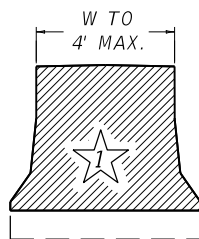

SECTION B-B

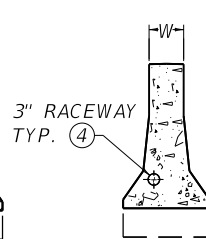

NORMAL SECTION C-C

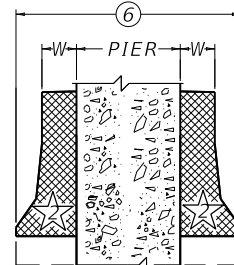

SECTION D-D

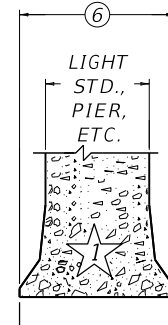

SECTION E-E

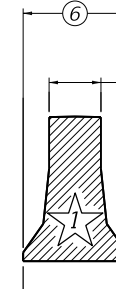

SECTION F-F

USE WITH CUR. STD. DWG. **RBM-050**

KENTUCKY
DEPARTMENT OF HIGHWAYS
CONCRETE MEDIAN BARRIER
SYMMETRICAL & ASYMMETRICAL
SEPARATE & TRANSITION
DETAILS (50" TALL WALL)

STANDARD DRAWING NO. **RBM-060-01**

SUBMITTED *[Signature]* 12-01-15
DATE
APPROVED *[Signature]* 12-01-15
DATE
STATE HIGHWAY ENGINEER